

BALL VALVES

COMPACT PATTERN PVC BALL VALVE

- Schedule 80 PVC
- White Body with Blue Handle
- Threaded and SXS Configurations
- Molded in Place Construction
- All Sizes One Piece Body
- ISO 9002 Manufacturer

No.	Part	Materials Specification
①	Body	PVC
②	Seat Seal	Santoprene
③	Ball and Stem	PVC
④	O Ring	EPDM, FPM
⑤	Handle	ABS
⑥	Cap	ABS

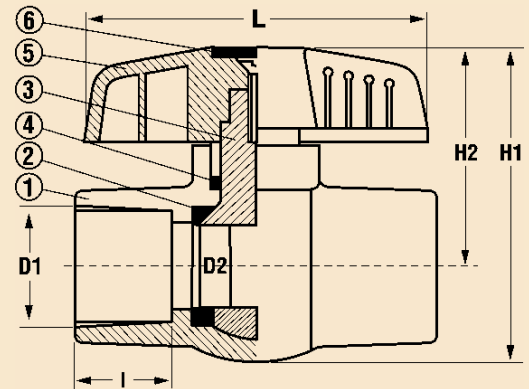

293 9121 SERIES

SCHEDULE 80 PVC BALL VALVE - THREADED*

Size	Fig. #	Weight	Box/Case	D1	D2	L	I	H1	H2
1/2"	293 9121G	0.20	1/80	0.85	0.59	3.15	0.89	2.44	1.83
3/4"	293 9121I	0.35	1/45	1.06	0.79	3.62	1.06	3.07	2.05
1"	293 9121K	0.68	1/25	1.33	0.95	3.86	1.10	3.66	2.56
1-1/4"	293 9121L	0.87	1/20	1.67	1.18	4.45	1.12	3.86	2.86
1-1/2"	293 9121M	1.35	1/14	1.91	1.34	5.16	1.34	4.53	2.90
2"	293 9121N	1.93	1/8	2.39	1.77	5.87	1.58	6.03	3.51
2-1/2"	293 9121P	4.70	1/16	2.89	2.36	8.04	1.73	6.30	4.14
3"	293 9121Q	5.60	1/12	3.52	3.03	9.02	2.01	7.49	4.89
4"	293 9121T	11.00	1/8	4.52	3.98	11.82	2.40	9.18	5.83



293 9122 SERIES

SCHEDULE 80 PVC BALL VALVE - SOCKET END

Size	Fig. #	Weight	Box/Case	D1	D2	L	I	H1	H2
1/2"	293 9122G	0.20	1/80	0.85	0.59	3.15	0.89	2.44	1.83
3/4"	293 9122I	0.35	1/45	1.06	0.79	3.62	1.06	3.07	2.05
1"	293 9122K	0.68	1/25	1.33	0.95	3.86	1.10	3.66	2.56
1-1/4"	293 9122L	0.87	1/20	1.67	1.18	4.45	1.12	3.86	2.86
1-1/2"	293 9122M	1.35	1/14	1.91	1.34	5.16	1.34	4.53	2.90
2"	293 9122N	1.93	1/8	2.39	1.77	5.87	1.58	6.03	3.51
2-1/2"	293 9122P	4.70	1/16	2.89	2.36	8.04	1.73	6.30	4.14
3"	293 9122Q	5.60	1/12	3.52	3.03	9.02	2.01	7.49	4.89
4"	293 9122T	11.00	1/8	4.52	3.98	11.82	2.40	9.18	5.83



Operating Temperature (F) 100 110 120 130 140
Pressure rating (PSI) 235 211 150 75 50

* Threaded Valves should not be used at temperatures above 110 F.