

SMITH-COOPER INTERNATIONAL PLUMBING ACCESSORIES

190 167II
190 120G
190 125G

HOSE END VACUUM BREAKER

- UPC / IAPMO Listed
- ASSE 1011 Listed
- Manufactured in Compliance with ASSE 1011-95
- Prevents Backflow
- Working Pressure 125 PSI @ 180 Degrees F
- ISO 9002 Manufacturer
- Rough Brass Finish
- Break Away Screw for Tamper Proof Installation

No.	Part	Materials Specification
①	3/4" MHT Cap	Brass JIS C36048B
②	3/4" FHT Base	Brass JIS C3604B
③	Securing Screw	Steel SAE 12L14
④	Flat Washer	Rubber NBR
⑤	Washer	Rubber NBR
⑥	Piston	Celcon M 90
⑦	Spring	Stainless Steel AISI 304

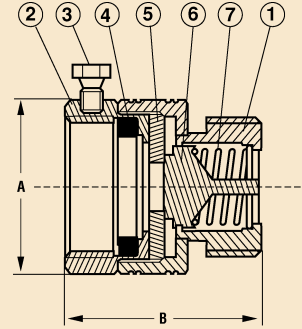

190 167II HOSE END VACUUM BREAKER, ROUGH BRASS FINISH (MHT X FHT)						
Size	Fig. #	Weight	Box/Case	A	B	
3/4"	190 167II	0.20	12/288	1.31	1.36	



WASHING MACHINE VALVE

- Cast Brass
- Chrome Plated
- Pipe Threads Comply with ANSI B1.20.1
- 3/4" Hose Thread Outlet
- Hose Threads Comply with ANSI B1.20.7

No.	Part	Materials Specification
①	Body	C.P. Cast Brass ASTM B-584, C85700
②	Bibb Washer	Rubber (NBR)
③	Stem	C.P. Cast Brass ASTM B-584, C85700
④	Handle	C.P. Zinc
⑤	Screw	C.P. Brass ASTM B-134, C27000
⑥	Packing Nut	C.P. Brass ASTM B-124, C37700
⑦	Packing Washer	Rubber (NBR)
⑧	S.S. Washer	Stainless Steel 304
⑨	Brass Ring	Brass ASTM B-124, C37700
⑩	Coupling Nut	C.P. Brass ASTM B-124, C37700

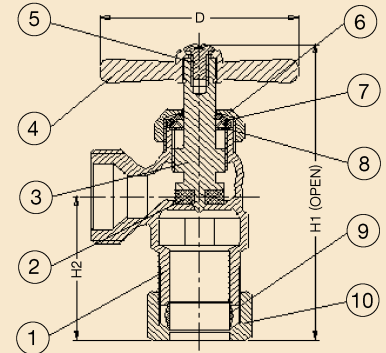

190 120 SERIES FIP WASHING MACHINE VALVE (FIP X MHT)						
Size	Fig. #	Weight	Box/Case	H1	H2	D
1/2"	190 120G	0.32	12/120	2.95	1.00	2.09

190 125 SERIES COMPRESSION INLET WASHING MACHINE VALVE (COMP X MHT)						
Size	Fig. #	Weight	Box/Case	H1	H2	D
1/2"	190 125G	0.37	12/120	3.50	1.56	2.09

