

# SMITH-COOPER

INTERNATIONAL

## CARBON STEEL BALL VALVE

**172 1000**  
**Series**

# ONE-PIECE CARBON STEEL BALL VALVE

- 2000 PSI/138 Bar Non-Shock Cold Working Pressure; 150 PSI Sat. Steam
- Stainless Steel Trim
- Fed. Spec. WW-V-35, Type II Class CS, Style 3.
- MSS SP-110
- ANSI B16.34
- Conforms to NACE MR-01-75
- NPT threads conform to ANSI B1.20.1
- Blow Out Proof Stem
- Reinforced TFE Seats
- Adjustable Packing Gland
- ISO 9002 Manufacturer

No.	Part	Materials Specification
①	Body	ASTM A108 - Carbon Steel
②	Seat	Reinforced TFE
③	Ball	ASTM A351-CF8/304
④	Thrust Washer	PTFE
⑤	Packing Nut	Zinc Plated Steel
⑥	Stem	ASTM A276-304
⑦	Handle Nut	Zinc Plated Steel
⑧	Handle Washer	Zinc Plated Steel
⑨	Stem Packing	PTFE
⑩	Gasket	PTFE
⑪	Retainer	ASTM A108 - Carbon Steel
⑫	Handle	Zinc Plated Steel
⑬	Handle Cover	PVC

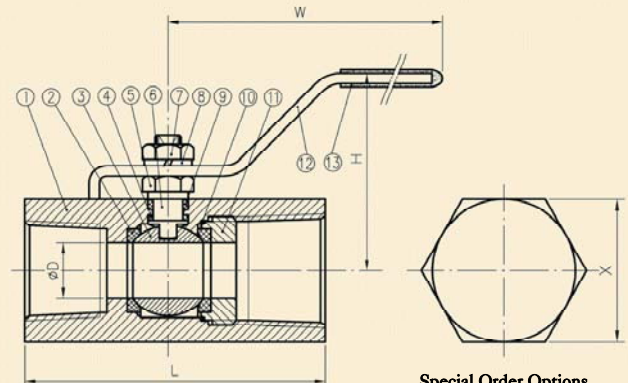

**Special Order Options**  
V - Vented Ball  
S - Stainless Steel Body



### DIMENSIONS

Size		ØD		L		H		W		X	
in	mm	in	mm	in	mm	in	mm	in	mm	in	mm
1/4"	8	0.20	5	1.69	43	1.22	31	2.64	67	0.67	17
3/8"	10	0.28	7	1.85	47	1.30	33	3.15	80	0.83	21
1/2"	15	0.36	9.2	2.44	62	2.20	56	4.33	110	1.14	29
3/4"	20	0.49	12.5	2.76	70	2.36	60	4.33	110	1.38	35
1"	25	0.63	16	3.39	86	2.56	65	4.80	122	1.61	41
1-1/4"	32	0.79	20	3.70	94	2.83	72	5.83	148	2.24	57
1-1/2"	40	0.98	25	4.02	102	2.83	72	5.83	148	2.4	57
2"	50	1.26	32	4.49	114	3.31	84	6.06	154	2.85	72.5

