

Lead Free

DIELECTRIC UNIONS

- California AB1953 Lead Free Approved
- Prevents Electrolysis
- Full Flow
- Forged Carbon Steel Nut, Zinc Plated

- Forged Carbon Steel IPS Connections, Zinc Plated
- Working Pressure 300 PSI @ 150 deg. F
- High Temperature Washer Available

No.	Part	Materials Specification
①	Nut	Forged Carbon Steel ASTM A197
②	Insulator	Nylon + Fiberglass Grilon TV-3H
③	Solder Connection	Brass ASTM B-124, C28000
④	Washer	EPDM Rubber
⑤	FIP Inlet	Forged Carbon Steel ASTM A197
⑥	Body	Cast Iron, JIS FC25
⑦	Solder Joint	Cast Brass, ASTM C85710
⑧	Bolt	Steel, AISI 1010
⑨	Nut	Steel, AISI 1010

• *For water use only*

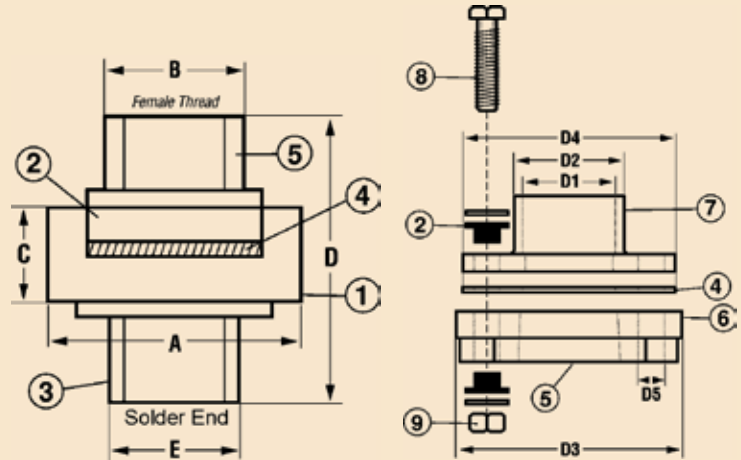

209 FXL SERIES DIELECTRIC UNION (FIP X SOLDER)

Size	Fig. #	Weight	Box/Case	A	B	C	D	E
1/2"	209 FXGL	0.346	12/144	1.63	1.04	0.72	1.85	0.82
3/4"	209 FXIL	0.434	12/144	1.85	1.26	0.72	2.03	1.07
3/4" x 1/2"	209 FXIGL	0.43	12/144	1.85	1.26	0.72	1.89	0.82
1"	209 FXKL	0.59	12/120	2.14	1.54	0.73	2.26	1.31
1 1/4"	209 FXLL	0.86	6/48	2.56	1.86	0.85	2.52	1.57
1 1/2"	209 FXML	1.42	6/48	2.95	2.15	0.97	2.53	1.83
2"	209 FXNL	2.67	6/24	3.76	2.73	1.06	2.85	2.54

