

LEAD FREE

BRASS SWING CHECK VALVES

- 200# WOG / 125# WSP
- California AB1953 Lead Free Approved
- ANSI/NSF 61.8 Approved

- Cast Brass
- Forged Brass Disc
- Machined Sealing Surface
- ISO 9001 Manufacturer

No. Part	Materials Specification
① Cap	Cast Brass ASTM B584-C89550
② Body	Cast Brass ASTM B584-C89550
③ Disc	Cast Brass ASTM B584-C89550
④ Pin	Brass ASTM B16-C36000
⑤ Screw	Brass ASTM B16-C36000

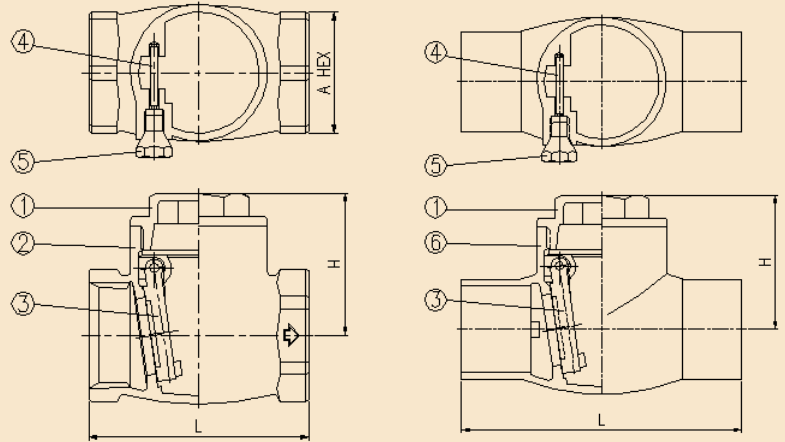

173 9191L SERIES SWING CHECK VALVE, THREADED

Size	Fig. #	Weight	Box/Case	L	H
1/2"	173 9191GL	0.34	10/160	2.05	1.50
3/4"	173 9191IL	0.62	10/120	2.32	1.58
1"	173 9191KL	0.90	6/72	2.72	1.77
1-1/4"	173 9191LL	1.33	5/60	3.11	2.01
1-1/2"	173 9191ML	1.84	4/32	3.51	2.17
2"	173 9191NL	2.75	2/24	4.29	2.64



173 9192L SERIES SWING CHECK VALVE, SOLDER END

Size	Fig. #	Weight	Box/Case	L	H
1/2"	173 9192GL	0.43	10/160	2.09	1.50
3/4"	173 9192IL	0.63	10/120	2.96	1.58
1"	173 9192KL	0.76	6/72	3.62	1.77
1-1/4"	173 9192LL	1.37	5/60	4.06	2.01
1-1/2"	173 9192ML	1.94	4/32	4.53	2.17
2"	173 9192NL	3.04	2/24	5.48	2.64

