

**Lead Free**

## FULL PORT BALL VALVES

- 600# WOG, 150# WSP
- Full Port
- California AB1953 Lead Free Approved
- Approved to NSF/ANSI 61 Low Lead Standard
- Forged Brass
- PTFE Seats
- Blow Out Proof Stem
- ISO 9001 Manufacturer

No. Part	Materials Specification
① Body	Forged Brass ASTM B-455, C28000
② Body End Cap	Forged Brass ASTM B-455, C28000
③ Ball Seat	PTFE
④ Ball	Chrome Plated Brass ASTM B-124, C28000 (1/4" - 1") Stainless Steel 304 (1-1/4" - 2")
⑤ Stem	Brass ASTM B-455, C28000
⑥ Stem Packing	PTFE
⑦ Packing Nut	Brass ASTM B-124, C37700
⑧ Handle	Forged Steel ASTM A-283 (Zinc Plated)
⑨ Nut	Forged Steel ASTM A-283 (Zinc Plated)

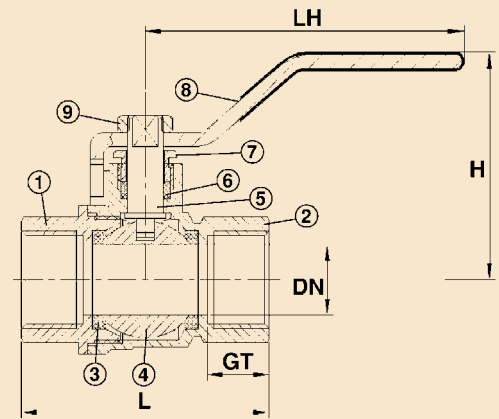

172 8145L SERIES								
BRASS BALL VALVE, THREADED								
Size	Fig. #	Weight	Box/Case	DN	L	H	GT	LH
1/4"	172 8145 CL	.35	12/120	.394	1.73	1.8	0.39	3.43
3/8"	172 8145 EL	.35	12/120	.394	1.73	1.8	0.45	3.43
1/2"	172 8145 GL	.37	8/96	.517	1.90	2.0	0.46	3.43
3/4"	172 8145 IL	.60	6/72	.743	2.28	2.3	0.55	3.70
1"	172 8145 KL	.89	10/40	.915	2.64	2.6	0.63	4.60
1-1/4"	172 8145 LL	1.30	7/28	1.25	3.11	2.8	0.70	4.60
1-1/2"	172 8145 ML	2.00	2/16	1.45	3.59	3.3	0.80	5.60
2"	172 8145 NL	2.98	2/12	1.94	4.15	3.6	0.83	5.60



172 8146L SERIES								
BRASS BALL VALVE, SOLDER END								
Size	Fig. #	Weight	Box/Case	DN	L	H	GT	LH
1/2"	172 8146 GL	.37	8/96	.517	2.13	1.60	0.50	3.43
3/4"	172 8146 IL	.56	6/72	.743	2.78	1.70	0.75	3.70
1"	172 8146 KL	.89	8/48	.915	3.43	2.40	0.87	4.60
1-1/4"	172 8146 LL	1.30	6/24	1.25	3.84	2.50	0.97	4.60
1-1/2"	172 8146 ML	2.00	2/16	1.45	4.27	2.80	1.10	5.60
2"	172 8146 NL	3.40	1/8	1.94	5.10	3.00	1.34	5.60

