

## STANDARD PORT LOW LEAD BALL VALVES

- 400# WOG, 150# WSP
- Standard Port
- Chrome Plated Brass Ball
- Approved to NSF/ANSI 61 Low Lead Standard
- Forged Brass
- Blow Out Proof Stem
- PTFE Seats
- ISO 9001 Manufacturer

No. Part	Materials Specification
① Body	Forged Brass ASTM B-455, C38500
② Body End Cap	Forged Brass ASTM B-455, C38500
③ Ball Seat	PTFE
④ Ball	Chrome Plated Brass ASTM B-124, C37700
⑤ Stem	Brass ASTM B-124, C37700
⑥ Stem Packing	PTFE
⑦ Packing Nut	Brass ASTM B-124, C37700
⑧ Handle	Forged Steel ASTM A-283 (Zinc Plated)
⑨ Nut	Forged Steel ASTM A-283 (Zinc Plated)

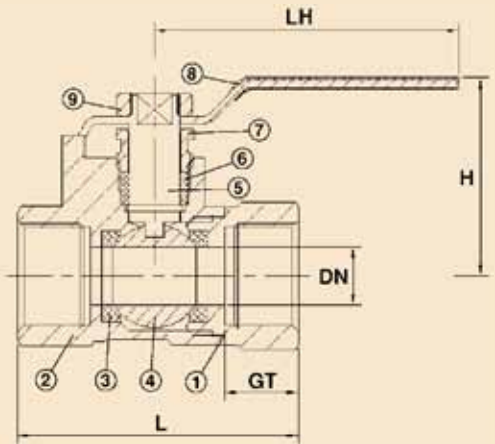

172 8135 SERIES BRASS BALL VALVE, THREADED								
Size	Fig. #	Weight	Box/Case	DN	L	H	GT	LH
1/4"	172 8135 C	.32	12/120	.37	1.73	1.47	.45	3.43
3/8"	172 8135 E	.32	12/120	.47	1.73	1.47	.45	3.43
1/2"	172 8135 G	.36	12/120	.47	1.91	1.61	.49	3.43
3/4"	172 8135 I	.48	8/96	.59	2.07	1.73	.51	3.43
1"	172 8135 K	.84	10/60	.79	2.64	2.24	.69	4.65
1-1/4"	172 8135 L	1.12	8/32	.98	2.97	2.38	.75	4.65
1-1/2"	172 8135 M	1.62	4/24	1.26	3.29	2.80	.75	5.47
2"	172 8135 N	2.34	2/16	1.57	3.68	2.99	.75	5.47
2-1/2"	172 8135 P	7.89	2/8	1.97	4.74	3.76	1.00	7.72
3"	172 8135 Q	11.68	2/4	2.52	5.47	5.14	1.04	9.69
4"	172 8135 T	22.11	2/4	3.11	6.50	5.61	1.06	9.45



172 8136 SERIES BRASS BALL VALVE, SOLDER ENDS								
Size	Fig. #	Weight	Box/Case	DN	L	H	GT	LH
1/2"	172 8136 G	0.34	12/120	.394	2.13	1.61	.63	3.43
3/4"	172 8136 I	0.49	8/96	.591	2.78	1.73	.86	3.43
1"	172 8136 K	0.89	8/48	.787	3.43	2.24	1.02	4.65
1-1/4"	172 8136 L	1.12	6/36	.984	3.84	2.38	1.18	4.65
1-1/2"	172 8136 M	1.62	2/16	1.26	4.27	2.80	1.20	5.47
2"	172 8136 N	2.47	2/12	1.535	5.08	2.99	1.44	5.47

