

PLUMBING VALVES

FLANGED SILLCOCKS

- Cast Brass
- 3/4" Hose Thread Outlet
- Cast Iron Handle
- Pipe Threads Comply with ANSI B1.20.1
- Hose Threads Comply with ANSI B1.20.7
- Complies with NSF 61.8 (Low Lead), Premium Grade
- ISO 9001 Manufacturer, Premium Grade
- Part # 190 112GVB installed w/vacuum breaker

No.	Part	Materials Specification
①	Handle Nut	Steel ASTM AISI-1010
②	Name Plate	Aluminum ASTM B209-1100
③	Handwheel	Cast Iron ASTM A48 Class/NO.35
④	Stem	Cast Brass B584-C85700
⑤	Packing Nut	Brass B16-C36000
⑥	Gland Packing	PTFE
⑦	Bonnet	Cast Brass B584-C85700
⑧	Body	Cast Brass B584-C85700
⑨	Bibb Washer	Rubber (NBR)
⑩	Seat Packing Screw	Brass B134-C27000

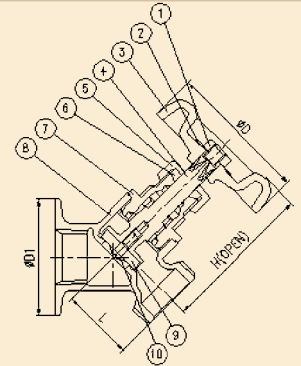

190 112 SERIES

PREMIUM FLANGED SILLCOCK, NSF APPROVED (FIP X MHT)

Size	Fig. #	Weight	Box/Case	L	H	D
1/2"	190 112G	0.50	10/60	1.10	2.52	2.13
3/4"	190 112I	0.55	4/48	1.10	2.52	2.13



No.	Part	Materials Specification
①	Body	Cast Brass ASTM B-584, C85700
②	Stem	Cast Brass ASTM B-584, C85700
③	Handwheel	Cast Iron ASTM A48 Class/NO.35
④	Name Plate	Aluminum ASTM B209-1100
⑤	Handle Nut	Brass Plate Steel ASTM AISI-1010
⑥	Packing Nut	Brass ASTM B-124, C37700
⑦	Packing Washer	Rubber (NBR)
⑧	Washer	Stainless Steel 304
⑨	Bibb Washer	Rubber (NBR)

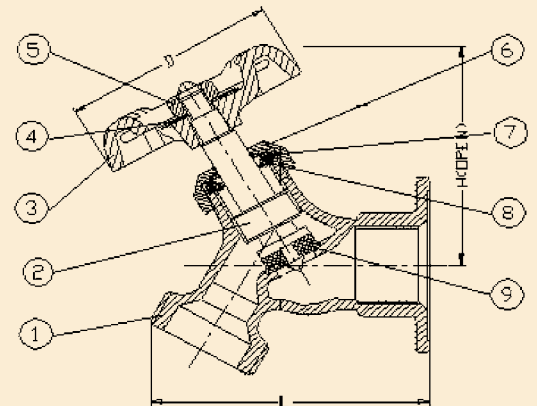

190 110 SERIES

ECONOMY FLANGED SILLCOCK (FIP X MHT)

Size	Fig. #	Weight	Box/Case	L	H	D
1/2"	190 110G	0.47	12/72	2.44	2.36	2.00
3/4"	190 110I	0.48	12/72	2.44	2.48	2.00
1/2"	190 115G*	0.47	12/72	2.44	2.36	2.00



* 190 115G, Satin Nickel Finish