

BOILER DRAINS

PREMIUM BOILER DRAIN VALVES

- 125# WOG
- Cast Brass
- ANSI/NSF 61-8 Approved (Low Lead)
- CSA Approved
- ISO 9001 Manufacturer
- With Stuffing Box

No.	Part	Material Specifications
1	Nut	Forged Steel ASTM - AISI-1010
2	Name Plate	Aluminum ASTM B-209, Alloy 1100
3	Handwheel	Cast Iron ASTM A-48, Class No. 35
4	Stem	Cast Brass ASTM B-584, C85700
5	Packing Nut	Brass ASTM B-16, C36000
6	Packing	PTFE
7	Bonnet	Cast Brass ASTM B-584, C85700
8	Body	Cast Brass ASTM B584, C85700
9	Seat Disk	NBR
10	Seat Disk Screw	Brass ASTM B-134, C27000

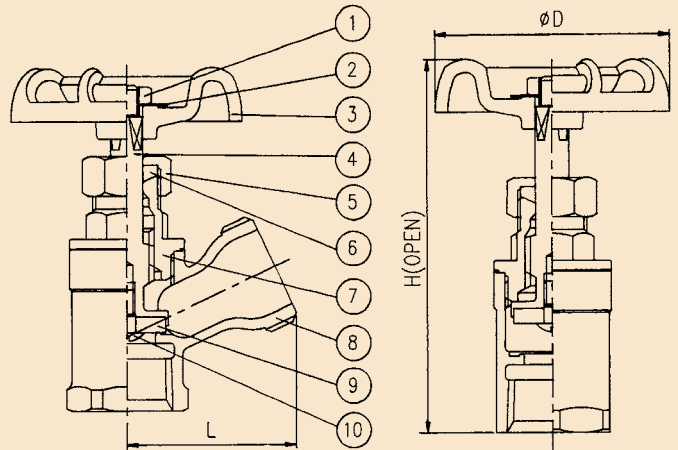

190 102 SERIES FEMALE BOILER DRAIN, FIP X MHT

Size	Part #	Weight	Box/Case	L	H	D
1/2	190 102 G	.42	12/72	1.57	3.31	2.13
3/4	190 102 I	.47	12/72	1.57	3.35	2.13



190 103 SERIES MALE BOILER DRAIN, MIP OR 1/2" SOLDER INLET X MHT

Size	Part #	Weight	Box/Case	L	H	D
1/2	190 103 G	.49	12/72	1.57	3.58	2.13
3/4	190 103 I	.52	12/72	1.57	3.70	2.13



190 106 SERIES COMPRESSION BOILER DRAIN, COMPRESSION X MHT

Size	Part #	Weight	Box/Case	L	H	D
1/2	190 106 G	.54	12/72	1.57	3.65	2.13

