

SMITH-COOPER INTERNATIONAL

GAS VALVES

190 200/250 Series
190 230/235 Series

PREMIUM GAS BALL VALVES

- Forged Brass Body, Two Piece
- Blow Out Proof Stem
- CSA 3-88 5 psig, Z21.15a 1/2 psig
- 600 psi WOG
- Fed. spec. WW-V-35, Type II Class A Style 3
- ISO 9001:2000 Manufacturer
- ASME B16.33

No. Part	Materials Specification
① Nut	Forged Steel ASTM - AISI-1010, Die Chromplated
② Handle	Aluminum, Red Enamel
③ Washer	PTFE
④ O-Ring (2)	NBR
⑤ Stem	Forged Brass ASTM B-124, C37700
⑥ Washer	PTFE
⑦ Body	Forged Brass ASTM B-124, C37700
⑧ Ball	Chrome Plated, Brass ASTM B-16, C37700
⑨ Seat Rings (2) PTFE	
⑩ Body End Cap	Forged Brass ASTM B-124, C37700

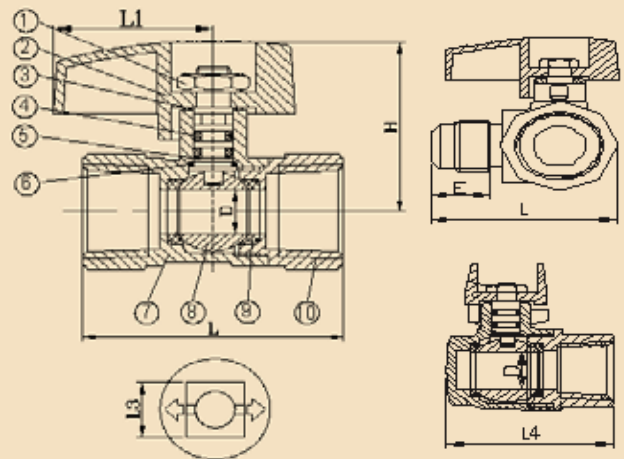

190 200 SERIES

GAS BALL VALVE, THREADED (FIP X FIP)

Size	Fig. #	Wt.	Box/Case	L	H	D	L1		
3/8	190 200 E	0.24	12/144	1.77	1.48	0.39	1.26		
1/2	190 200 G	0.33	12/144	2.13	1.50	0.39	1.26		
3/4	190 200 I	0.53	8/96	2.44	1.63	0.55	1.26		
1	190 200 K	1.05	6/72	3.13	1.86	0.94	1.26		

190 250 SERIES FLAT

HEAD GAS BALL VALVE, THREADED (FIP X FIP)

Size	Fig. #	Wt.	Box/Case	L	H	D	L3		
1/2	190 250 G	0.40	12/144	2.13	1.63	0.39	0.48		
3/4	190 250 I	0.59	8/96	2.44	1.74	0.55	0.48		

190 230 SERIES

GAS BALL VALVE, FLARE (FIP X FLARE)

Size	Fig. #	Wt.	Box/Case	L	H	D	L1	E	
1/2 x 3/8	190 230 GE	0.35	12/144	2.48	1.50	0.39	1.26	0.53	
1/2 x 1/2	190 230 GG	0.37	12/144	2.68	1.50	0.39	1.26	0.70	
3/4 x 5/8*	190 230 IH	0.56	8/96	2.99	1.60	0.55	1.26	0.79	

190 235 SERIES

ANGLE GAS BALL VALVE, FLARE (FIP X FLARE)

Size	Fig. #	Wt.	Box/Case	L	H	D	L1	E	L4
1/2 x 3/8	190 235 GE	0.33	6/96	2.48	1.50	0.39	1.26	0.50	1.90
1/2 x 1/2	190 235 GG	0.47	6/96	2.68	1.50	0.39	1.26	0.70	2.08
3/4 x 5/8*	190 235 IH	0.57	6/96	2.99	1.60	0.55	1.26	0.79	2.22



*5/8 Flare Connection has 15/16-16 Threads