

CHECK VALVES

RESILIENT SEAT AWWA SWING CHECK VALVE

- 200# W (2-12")
- AWWA C508
- Gray Iron ASTM A 126, class B Body
- MSS-SP-71

- Epoxy Coated ANSI/AWWA C550
- Resilient Seat
- 4 Boss Design
- Flanged Ends

No.	Part	Material Specifications
1	Body	Gray Iron, ASTM A126 Class B
2	Body Seat Ring	Bronze, ASTM B62
3	Disc	Ductile Iron, EPDM Coated
4	Disc Washer	EPDM
5	Disc Washer	Steel A307 Grade B
6	Disc Bolt/Washer	Stainless Steel, Type 304
7	Bolt/Pin/Nut/ Washer	Stainless Steel, Type 304
8	Pin	Stainless Steel, Type 304
9	Key	Stainless Steel, Type 304
10	Cover O-Ring	EPDM
11	Cover Bolt/ Washer	Steel A307 Grade B
12	O-Ring	EPDM
13	Hinge Bolt	Stainless Steel, Type 304
14	Washer	Stainless Steel, Type 304
15	Bushing	Stainless Steel, Type 304
16	Retainer	Stainless Steel, Type 304
17	O-Ring	EPDM
18	Packing Bolt	Steel A307 Grade B
19	Bolt/Nut	Steel A307 Grade B
20	Lever Arm	Steel A307 Grade B
21	Weight	Gray Iron, ASTM A126 Class B, Zinc Plated
22	Lock Bolt/Nut	Steel A307 Grade B
23	Cover	Gray Iron, ASTM A126 Class B
24	Arm	Stainless Steel CF8

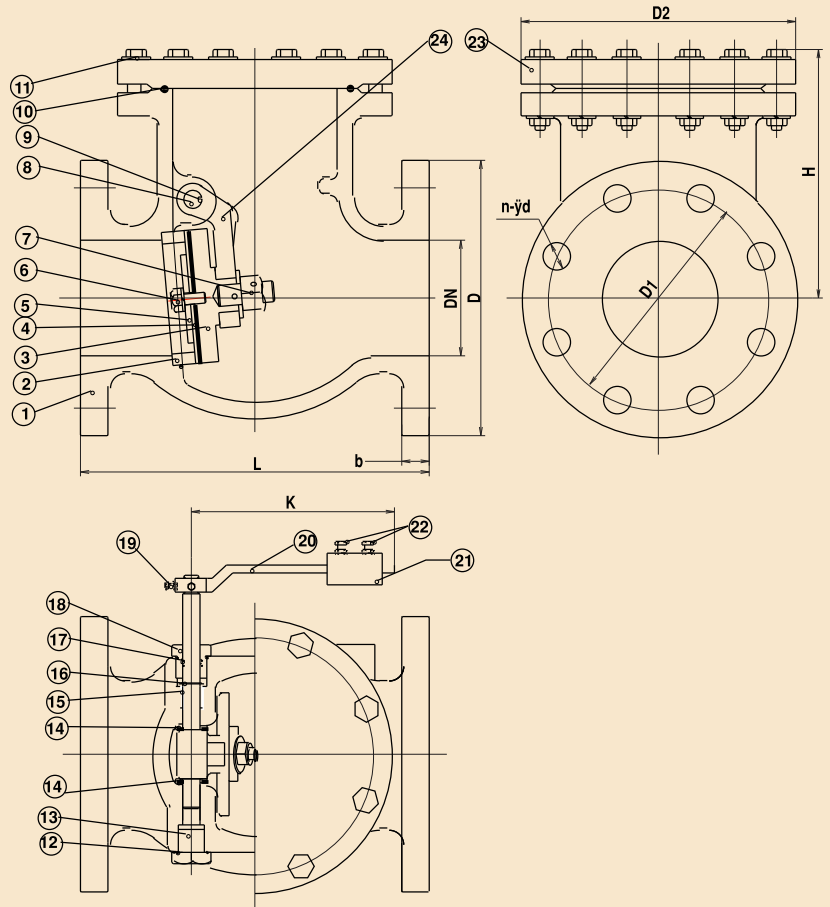

Spring kit available upon request.

0173 20FCW SERIES
CAST IRON AWWA SWING CHECK VALVE WITH LEVER AND WEIGHT

Size	Weight	D	D1	n-d	b	L	H	D2	R
2"	21	6.0	4.75	4-.75	0.62	8.0	5.5	6.1	5.5
2-1/2"	27	7.0	5.5	4-.75	0.69	8.5	6.6	6.9	5.5
3"	30	7.5	6.0	4-.75	0.75	9.5	6.9	7.5	5.9
4"	55	9.0	7.5	8-.75	0.94	11.5	8.3	9.0	7.9
6"	74	11.0	9.5	8-.88	1.00	14.0	10.0	11.0	9.9
8"	139	13.5	11.75	8-.88	1.12	19.5	12.4	13.4	13.8
10"	200	16.0	14.25	12-1.00	1.19	24.5	13.9	16.7	17.8
12"	294	19.0	17.0	12-1.00	1.25	27.5	16.2	19.0	17.8

