

BALL VALVES

ECONOMY FULL PORT BALL VALVES

- 600# WOG, 150# WSP
- Full Port
- Chrome Plated Brass Ball
- CSA 3-88 for 5 psig (1/2" - 2")
- CSA-Z21.15a for 1/2 psig (1/2" - 2")
- Blow Out Proof Stem
- PTFE Seats and Seals
- ISO 9001 Manufacturer

No.	Part	Materials Specification
①	Body	Forged Brass ASTM B-124, C37700
②	Body End Cap	Forged Brass ASTM B-124, C37700
③	Ball Seat	PTFE
④	Ball	Chrome Plated Brass ASTM B-124, C37700
⑤	Stem	Brass ASTM B-124, C37700
⑥	Stem Packing	PTFE
⑦	Packing Nut	Brass ASTM B-124, C37700
⑧	Handle	Forged Steel ASTM A-283 (Zinc Plated)
⑨	Nut	Forged Steel ASTM A-283 (Zinc Plated)

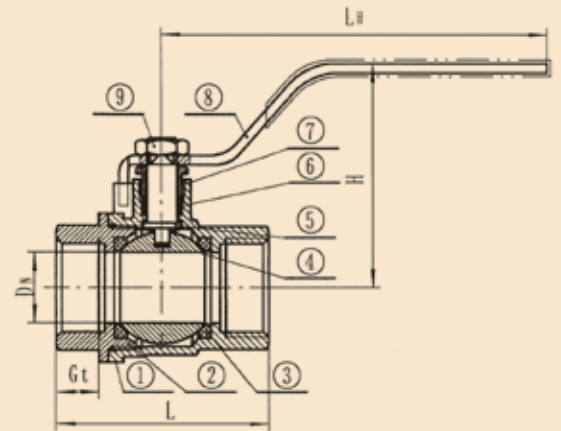

172 8155 SERIES BRASS BALL VALVE, THREADED

Size	Fig. #	Weight	Box/Case	DN	L	H	GT	LH
1/4"	172 8155 C	0.32	10/160	0.39	1.69	1.62	0.39	3.47
3/8"	172 8155 E	0.39	10/160	0.39	1.69	1.62	0.39	3.47
1/2"	172 8155 G	0.44	10/120	0.59	2.07	1.85	0.51	3.47
3/4"	172 8155 I	0.71	10/60	0.79	2.38	2.13	0.55	4.33
1"	172 8155 K	1.05	6/60	0.99	2.90	2.29	0.66	4.33
1-1/4"	172 8155 L	1.65	4/24	1.26	3.27	2.80	0.67	5.71
1-1/2"	172 8155 M	2.35	4/16	1.58	3.62	3.00	0.68	5.71
2"	172 8155 N	3.31	2/16	1.97	4.41	3.27	0.87	5.71
2-1/2"	172 8155 P	7.89	1/6	2.55	6.00	4.50	1.06	9.25
3"	172 8155 Q	11.68	1/3	2.95	6.50	4.92	1.87	9.25
4"	172 8155 T	22.11	1/2	3.94	7.75	5.75	1.90	10.39



172 8156 SERIES BRASS BALL VALVE, SOLDER END

Size	Fig. #	Weight	Box/Case	DN	L	H	GT	LH
1/2"	172 8156 G	0.42	10/120	0.59	2.24	1.85	0.50	3.47
3/4"	172 8156 I	0.66	10/60	0.79	2.82	2.13	0.75	4.33
1"	172 8156 K	0.99	6/60	0.99	3.31	2.29	0.87	4.33
1-1/4"	172 8156 L	1.65	4/24	1.26	4.14	2.80	1.10	5.71
1-1/2"	172 8156 M	2.29	4/16	1.58	4.45	3.00	1.10	5.71
2"	172 8156 N	3.31	2/16	1.97	5.35	3.27	1.34	5.71

