

GATE VALVES

RESILIENT WEDGE DUCTILE IRON – MECHANICAL JOINT X FLANGED

- Mechanical Joint x Flanged
- Ductile Iron Body and Bonnet
- 250 PSI Non-Shock Cold Working Pressure
- Non-Rising Stem
- Fusion Bonded Epoxy Coating conforms to AWWA C550
- Stainless Steel Stem
- Stainless Steel Bonnet Bolts
- Meets AWWA C515

No.	Part	Materials Specification
①	Body	Ductile Iron A536 65/45/12
②	Wedge	Ductile Iron A536 65/45/12; Buna-N
③	Wedge Nut	Bronze B584 C83600
④	Stem	Stainless Steel 304
⑤	Bonnet	Ductile Iron A536 65/45/12
⑥	Packing Gland	Ductile Iron A536 65/45/12
⑦	Stem Wiper	Buna-N
⑧	Operating Nut	Ductile Iron A536 65/45/12
⑨	Handle Bolt	Stainless Steel 304
⑩	Bonnet O-Ring	Buna-N
⑪	Bonnet Bolts	Stainless Steel 304
⑫	Gasket	Buna-N
⑬	Packing/Bonnet O-Ring	Buna-N
⑭	Packing/Gland O-Ring	Buna-N

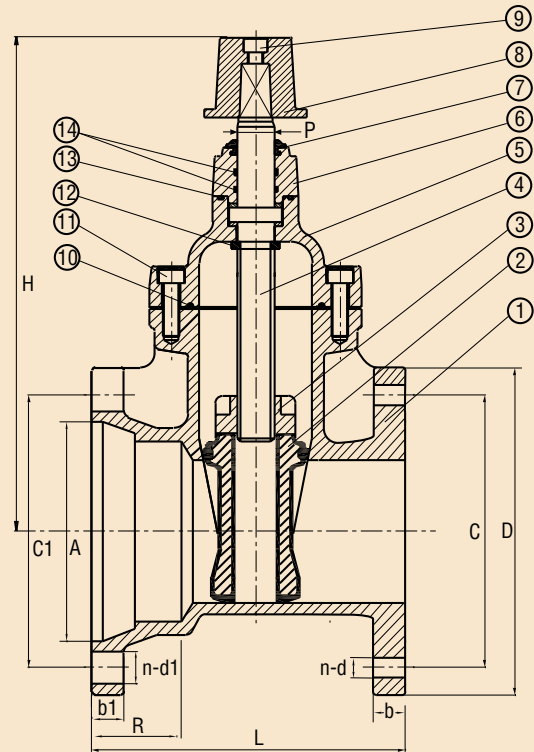

RESILIENT WEDGE DUCTILE IRON GATE VALVES MECHANICAL JOINT X FLANGED													
Size	Weight	L	H	C1	C	D	b	b1	n-d1	n-d	A	R	P
3"	50.7	8.00	12.24	6.19	6.00	7.50	0.75	0.87	4-0.750	4-0.750	4.94	2.50	0.87
4"	70.5	9.00	13.86	7.50	7.60	9.00	0.94	0.91	4-0.875	8-0.875	6.02	2.50	1.02
6"	143.3	10.50	19.09	9.50	9.50	11.00	1.00	0.98	6-0.875	8-0.875	8.12	2.50	1.14
8"	207.2	11.50	20.47	11.75	11.75	13.50	1.12	0.98	6-0.875	8-0.875	10.27	2.50	1.26
10"	321.9	13.00	24.88	14.00	14.25	16.00	1.19	0.98	8-0.875	12-0.980	12.34	2.50	1.42
12"	460.8	14.00	29.33	16.25	17.00	19.00	1.25	0.98	8-0.875	12-0.980	14.44	2.50	1.50
24"	1772	20.00	57.00	29.50	30.00	32.00	1.85	1.61	16-0.875	20-1.375	27.4	3.50	2.13

