

**BALL VALVES**

## NICKEL PLATED FULL PORT BALL VALVES

- 600# WOG, 150# WSP
- Full Port
- Chrome Plated Brass Ball
- CSA 3-88 for 5 psig (1/2" - 2")
- NSF/ANSI 61.8 Approved
- CSA-Z21.15a for 1/2" psig (1/2" - 2")
- Blow Out Proof Stem
- PTFE Seats and Seals
- ISO 9001 Manufacturer

No.	Part	Material Specifications
1	Body	Forged Brass ASTM B-124, C37700 (Zinc Plated)
2	Body End Cap	Forged Brass ASTM B-124, C37700
3	Ball Seat	PTFE
4	Ball	Chrome Plated Brass ASTM B-124, C37700
5	Stem	Brass ASTM B-124, C37700
6	Stem Packing	PTFE
7	Packing Nut	Brass ASTM B-124, C37700
8	Handle	Forged Steel ASTM A283 (Zinc Plated)
9	Nut	Forged Steel ASTM A-283 (Zinc Plated)

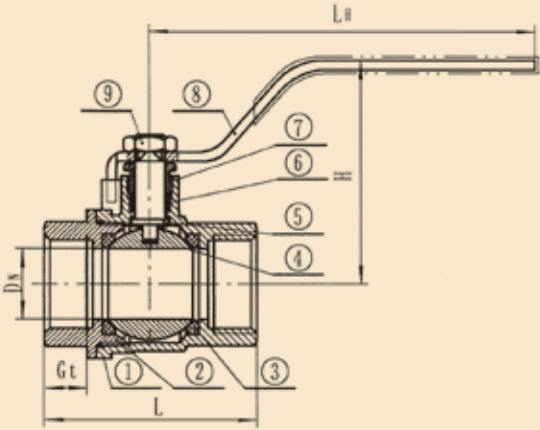

172 8160 SERIES BRASS BALL VALVE, THREADED								
Size	Part #	Weight	Box/Case	DN	L	H	GT	LH
1/4"	172 8160C	0.32	10/160	0.39	1.69	1.62	0.39	3.47
3/8"	172 8160E	0.39	10/160	0.39	1.69	1.62	0.39	3.47
1/2"	172 8160G	0.44	10/120	0.59	2.07	1.85	0.51	3.47
3/4"	172 8160I	0.71	10/60	0.79	2.38	2.13	0.55	4.33
1"	172 8160K	1.05	6/60	0.99	2.90	2.29	0.66	4.33
1-1/4"	172 8160L	1.65	4/24	1.26	3.27	2.80	0.67	5.71
1-1/2"	172 8160M	2.35	4/16	1.58	3.62	3.00	0.68	5.71
2"	172 8160N	3.31	2/16	1.97	4.41	3.27	0.87	5.71

