



SMITH - COOPER INTERNATIONAL



150# Malleable Iron Threaded Fittings

- * BLACK AND HOT-DIPPED GALVANIZED
- * ISO 9001:2000 MANUFACTURER
- * SCI BRAND IS UL LISTED & FM APPROVED

- *ANSI B16.3
- *ANSI B16.14
- *ANSI B 1.20.1
- *ASTM A197
- *ASTM A153
- *ASME B16.39
- * NON-SCI BRAND ITEMS ARE IN BOLD

Malleable Iron 90° Elbow

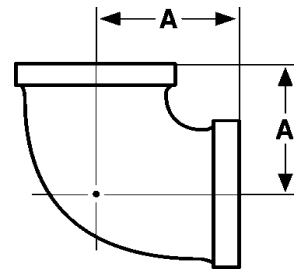
Figure 33E/34E	Size	A	Wgt
	1/8"	0.69	0.06
	1/4"	0.81	0.11
	3/8"	0.95	0.17
	1/2"	1.12	0.24
	3/4"	1.31	0.40
	1"	1.50	0.64
	1-1/4"	1.75	0.95
	1-1/2"	1.94	1.24
	2"	2.25	1.74
	2-1/2"	2.70	3.28
	3"	3.08	5.15
	3-1/2"	3.42	7.08
	4"	3.79	8.81
	5"	4.50	13.8
	6"	5.13	23.0
	8"	6.38	32.0

Malleable Iron Reducing 90° Elbow

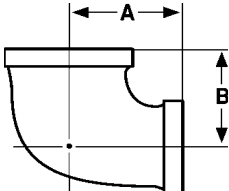
Fig. 33RE/34RE	Size	A	B	Wgt
	1/4 x 1/8	0.76	0.74	0.09
	3/8 x 1/8	0.85	0.81	0.11
	3/8 x 1/4	0.90	0.88	0.13
	1/2 x 1/8	0.98	0.96	0.17
	1/2 x 1/4	0.98	0.97	0.18
	1/2 x 3/8	1.04	1.03	0.20
	3/4 x 1/8	1.08	1.02	0.22
	3/4 x 1/4	1.08	1.05	0.25
	3/4 x 3/8	1.13	1.12	0.28
	3/4 x 1/2	1.22	1.20	0.36
	1 x 1/4	1.22	1.10	0.34
	1 x 3/8	1.27	1.18	0.40
	1 x 1/2	1.36	1.26	0.44
	1 x 3/4	1.45	1.37	0.53
	1-1/4 x 1/2	1.53	1.34	0.64
	1-1/4 x 3/4	1.62	1.45	0.75
	1-1/4 x 1	1.67	1.58	0.84
	1-1/2 x 1/2	1.75	1.52	0.90
	1-1/2 x 3/4	1.75	1.52	0.95
	1-1/2 x 1	1.80	1.65	0.99
	1-1/2 x 1-1/4	1.88	1.82	1.14
	2 x 1/2	1.97	1.60	1.35
	2 x 3/4	1.97	1.60	1.39
	2 x 1	2.02	1.73	1.58
	2 x 1-1/4	2.10	1.90	1.62
	2 x 1-1/2	2.16	2.02	1.67
	2-1/2 x 1/2	2.24	1.61	1.78
	2-1/2 x 3/4	2.30	1.73	2.00
	2-1/2 x 1	2.36	1.87	2.08
	2-1/2 x 1-1/4	2.44	2.03	2.24
	2-1/2 x 1-1/2	2.51	2.16	2.32
	2-1/2 x 2	2.60	2.39	3.01
	3 x 1/2	2.56	1.69	2.08
	3 x 3/4	2.60	1.87	2.40
	3 x 1	2.66	1.99	2.48
	3 x 1-1/4	2.74	2.16	2.50
	3 x 1-1/2	2.80	2.28	2.98
	3 x 2	2.89	2.52	3.70
	3 x 2-1/2	2.99	2.83	3.80
	4 x 1-1/4	3.39	2.40	4.70
	4 x 1-1/2	3.31	2.50	4.76
	4 x 2	3.41	2.74	5.14
	4 x 2-1/2	3.50	3.05	6.86
	4 x 3	3.60	3.30	7.55

Malleable Iron 45° Elbow

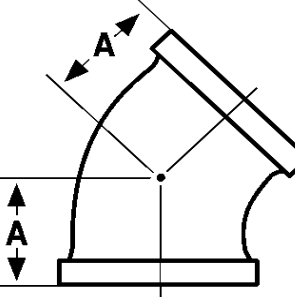
Figure 33F/34F	Size	A	Wgt
	1/8"	0.60	0.07
	1/4"	0.73	0.11
	3/8"	0.80	0.15
	1/2"	0.88	0.22
	3/4"	0.98	0.34
	1"	1.12	0.57
	1-1/4"	1.29	0.84
	1-1/2"	1.43	1.14
	2"	1.68	1.70
	2-1/2"	1.95	2.97
	3"	2.17	4.65
	4"	2.61	7.62
	5"	3.05	12.1
	6"	3.46	18.2
	8"	4.00	26.1

Malleable Iron Side Outlet Elbow

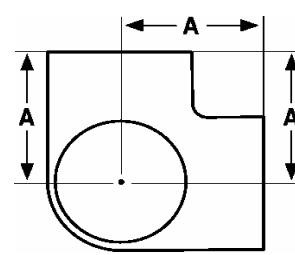
Figure 33OE/34OE	Size	A	Wgt
	1/8"	0.69	0.07
	1/4"	0.81	0.12
	3/8"	0.95	0.22
	1/2"	1.12	0.29
	3/4"	1.31	0.47
	1"	1.50	0.72
	1-1/4"	1.75	1.08
	1-1/2"	1.94	1.50
	2"	2.25	2.30



SMITH - COOPER INTERNATIONAL



150# Malleable Iron Threaded Fittings

* BLACK AND HOT-DIPPED GALVANIZED
* ISO 9001:2000 MANUFACTURER
* SCI BRAND IS UL LISTED & FM APPROVED

*ANSI B16.3 *ANSI B16.14 *ANSI B 1.20.1
*ASTM A197 *ASTM A153 *ASME B16.39
* NON-SCI BRAND ITEMS ARE IN BOLD

Malleable Iron Street 90° Elbow

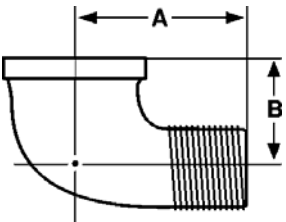
Figure 33SE / 34SE	Size	A	B	Wgt
	1/8"	1.00	0.69	0.06
	1/4"	1.19	0.81	0.10
	3/8"	1.44	0.95	0.17
	1/2"	1.61	1.12	0.25
	3/4"	1.89	1.30	0.40
	1"	2.13	1.50	0.65
	1-1/4"	2.44	1.75	1.08
	1-1/2"	2.67	1.94	1.46
	2"	3.27	2.25	2.34
	2-1/2"	3.86	2.70	4.11
	3"	4.51	3.08	6.59
	4"	5.69	3.79	10.9
	6"	8.03	5.13	23.2
Reducing Street 90° Elbow	Figure 33RS / 34RS			
Size	A	B	Wgt	
3/4" x 1/2"	1.73	1.16	0.30	
1" x 3/4"	2.03	1.37	0.45	
1-1/4" x 1"	2.41	1.60	0.70	

Malleable Iron Straight Tee

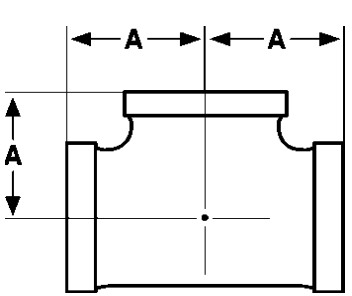
Figure 33T / 34T	Size	A	Wgt
	1/8"	0.69	0.09
	1/4"	0.81	0.15
	3/8"	0.95	0.23
	1/2"	1.12	0.36
	3/4"	1.31	0.56
	1"	1.50	0.90
	1-1/4"	1.75	1.30
	1-1/2"	1.94	1.73
	2"	2.25	2.63
	2-1/2"	2.70	4.90
	3"	3.08	7.10
	3-1/2"	3.42	9.00
	4"	3.79	11.30
	5"	4.50	19.40
	6"	5.13	25.50
	8"	6.50	44.70

Malleable Iron Street 45° Elbow

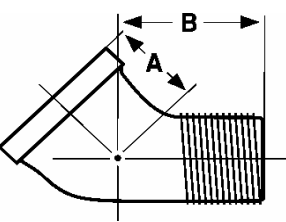
Figure 33SF / 34SF	Size	A	B	Wgt
	1/8"	1.00	0.69	0.06
	1/4"	0.73	0.94	0.10
	3/8"	0.80	1.03	0.12
	1/2"	0.88	1.15	0.22
	3/4"	0.98	1.29	0.34
	1"	1.12	1.47	0.54
	1-1/4"	1.29	1.71	0.85
	1-1/2"	1.43	1.88	1.21
	2"	1.68	2.22	1.95
	2-1/2"	1.95	2.57	2.65
	3"	2.17	3.00	4.36
	4"	2.61	3.70	7.00

Malleable Iron Side Outlet Tee

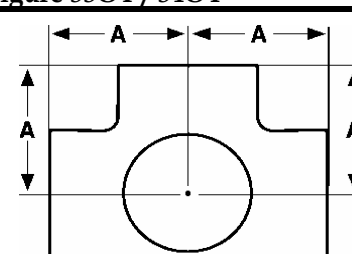
Figure 33OT / 34OT	Size	A	Wgt
	1/2"	1.12	0.36
	3/4"	1.31	0.56
	1"	1.50	0.90
	1-1/4"	1.75	1.30
	1-1/2"	1.94	1.73
	2"	2.25	2.63

Malleable Iron Service Tee

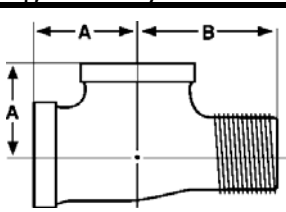
Figure 33ST / 34ST	Size	A	B	Wgt
	3/8"	0.95	1.44	0.23
	1/2"	1.12	1.63	0.36
	3/4"	1.31	1.89	0.56
	1"	1.50	2.14	0.90
	1-1/4"	1.75	2.45	1.34
	1-1/2"	1.94	2.69	1.93
	2"	2.25	3.26	3.16

Malleable Iron Cap

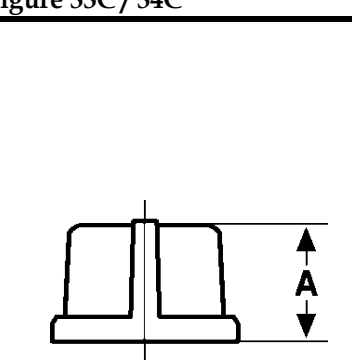
Figure 33C / 34C	Size	A	Wgt
	1/8"	0.53	0.05
	1/4"	0.63	0.07
	3/8"	0.74	0.11
	1/2"	0.87	0.15
	3/4"	0.97	0.22
	1"	1.16	0.35
	1-1/4"	1.28	0.54
	1-1/2"	1.33	0.68
	2"	1.45	0.96
	2-1/2"	1.70	1.72
	3"	1.80	2.55
	3-1/2"	1.90	3.12
	4"	2.08	4.60
	5"	2.32	6.42
	6"	2.55	9.90
	8"	3.20	16.9



SMITH - COOPER INTERNATIONAL



150# Malleable Iron Threaded Fittings

* BLACK AND HOT-DIPPED GALVANIZED
* ISO 9001:2000 MANUFACTURER
* SCI BRAND IS UL LISTED & FM APPROVED

*ANSI B16.3 *ANSI B16.14 *ANSI B1.20.1
*ASTM A197 *ASTM A153 *ASME B16.39
* NON-SCI BRAND ITEMS ARE IN BOLD

Malleable Iron Reducing Tee

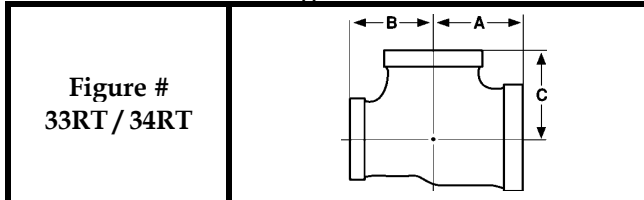

Figure #					
33RT / 34RT	Size	A	B	C	Wgt
	1/4 x 1/4 x 1/8	1.45	1.45	1.37	0.13
	3/8 x 3/8 x 1/8	0.81	0.81	0.86	0.20
	3/8 x 3/8 x 1/4	0.81	0.81	0.86	0.18
	1/2 x 3/8 x 3/8	1.04	0.95	1.03	0.28
	1/2 x 3/8 x 1/2	1.12	1.03	1.12	0.33
	1/2 x 1/2 x 1/8	0.91	0.91	0.97	0.24
	1/2 x 1/2 x 1/4	0.97	0.97	0.98	0.27
	1/2 x 1/2 x 3/8	1.04	1.04	1.03	0.30
	3/4 x 3/8 x 3/4	1.31	1.13	1.31	0.46
	3/4 x 1/2 x 1/2	1.20	1.12	1.22	0.43
	3/4 x 1/2 x 3/4	1.31	1.22	1.31	0.51
	3/4 x 3/4 x 1/4	1.12	1.12	1.12	0.38
	3/4 x 3/4 x 3/8	1.12	1.12	1.13	0.42
	3/4 x 3/4 x 1/2	1.20	1.20	1.22	0.46
	1 x 1/2 x 1/2	1.26	1.12	1.36	0.55
	1 x 1/2 x 3/4	1.37	1.22	1.45	0.56
	1 x 1/2 x 1	1.50	1.36	1.50	0.76
	1 x 3/4 x 1/2	1.26	1.20	1.36	0.59
	1 x 3/4 x 3/4	1.38	1.31	1.45	0.73
	1 x 1 x 1/4	1.12	1.12	1.25	0.55
	1 x 1 x 3/8	1.18	1.18	1.27	0.60
	1 x 1 x 1/2	1.26	1.26	1.36	0.66
	1 x 1 x 3/4	1.38	1.38	1.45	0.76
	1-1/4 x 1/2 x 1/2	1.36	1.12	1.53	0.64
	1-1/4 x 1/2 x 3/4	1.45	1.26	1.53	0.72
	1-1/4 x 1/2 x 1	1.58	1.36	1.67	0.87
	1-1/4 x 1/2 x 1-1/4	1.75	1.53	1.75	1.04
	1-1/4 x 3/4 x 1/2	1.34	1.12	1.53	0.76
	1-1/4 x 3/4 x 3/4	1.45	1.31	1.62	0.86
	1-1/4 x 3/4 x 1	1.58	1.45	1.67	0.96
	1-1/4 x 3/4 x 1-1/4	1.75	1.62	1.75	1.09
	1-1/4 x 1 x 1/2	1.34	1.26	1.53	0.81
	1-1/4 x 1 x 3/4	1.45	1.38	1.63	0.90
	1-1/4 x 1 x 1	1.58	1.50	1.69	1.03
	1-1/4 x 1 x 1-1/4	1.75	1.69	1.75	1.10
	1-1/4 x 1-1/4 x 3/8	1.26	1.26	1.44	0.86
	1-1/4 x 1-1/4 x 1/2	1.34	1.34	1.53	0.87
	1-1/4 x 1-1/4 x 3/4	1.45	1.45	1.62	0.96
	1-1/4 x 1-1/4 x 1	1.58	1.58	1.67	1.10

Malleable Iron Reducing Tee (con't)

Size	A	B	C	Wgt
1-1/2 x 1/2 x 1/2	1.35	1.08	1.67	0.80
1-1/2 x 1/2 x 3/4	1.56	1.18	1.80	0.88
1-1/2 x 1/2 x 1	1.65	1.35	1.80	0.90
1-1/2 x 1/2 x 1-1/4	1.81	1.56	1.88	1.37
1-1/2 x 1/2 x 1-1/2	1.94	1.66	1.94	1.42
1-1/2 x 3/4 x 1/2	1.35	1.12	1.77	0.78
1-1/2 x 3/4 x 3/4	1.55	1.35	1.77	1.00
1-1/2 x 3/4 x 1	1.82	1.35	1.88	1.08
1-1/2 x 3/4 x 1-1/4	1.94	1.66	1.88	1.42
1-1/2 x 3/4 x 1-1/2	1.94	1.75	1.94	1.47
1-1/2 x 1 x 1/2	1.44	1.25	1.69	0.97
1-1/2 x 1 x 3/4	1.50	1.44	1.75	1.14
1-1/2 x 1 x 1	1.65	1.50	1.80	1.14
1-1/2 x 1 x 1-1/4	1.82	1.67	1.88	1.47
1-1/2 x 1 x 1-1/2	1.94	1.80	1.94	1.52
1-1/2 x 1-1/4 x 1/2	1.41	1.34	1.66	1.03
1-1/2 x 1-1/4 x 3/4	1.52	1.45	1.75	1.10
1-1/2 x 1-1/4 x 1	1.65	1.58	1.80	1.31
1-1/2 x 1-1/4 x 1-1/4	1.82	1.75	1.88	1.52
1-1/2 x 1-1/4 x 1-1/2	1.94	1.88	1.94	1.50
1-1/2 x 1-1/2 x 3/8	1.36	1.36	1.66	1.08
1-1/2 x 1-1/2 x 1/2	1.41	1.41	1.66	1.14
1-1/2 x 1-1/2 x 3/4	1.52	1.52	1.75	1.23
1-1/2 x 1-1/2 x 1	1.65	1.65	1.80	1.38
1-1/2 x 1-1/2 x 1-1/4	1.82	1.82	1.88	1.50
2 x 1/2 x 2	2.25	1.88	2.25	2.14
2 x 3/4 x 3/4	1.65	1.31	1.92	1.20
2 x 3/4 x 2	2.25	1.97	2.25	2.00
2 x 1 x 1	1.78	1.45	2.08	1.44
2 x 1 x 1-1/2	2.10	1.88	2.18	1.84
2 x 1 x 2	2.25	2.02	2.25	2.18
2 x 1-1/4 x 1	1.78	1.65	2.10	1.52
2 x 1-1/4 x 1-1/4	1.90	1.75	2.10	1.72
2 x 1-1/4 x 1-1/2	2.00	1.88	2.18	1.85
2 x 1-1/4 x 2	2.25	2.10	2.25	2.31
2 x 1-1/2 x 3/4	1.60	1.52	1.97	1.61
2 x 1-1/2 x 1	1.73	1.65	2.02	1.65
2 x 1-1/2 x 1-1/4	1.90	1.82	2.10	2.03
2 x 1-1/2 x 1-1/2	2.02	1.94	2.16	2.37
2 x 1-1/2 x 2	2.25	2.16	2.25	2.53
2 x 2 x 3/8	1.49	1.49	1.88	1.45
2 x 2 x 1/2	1.49	1.49	1.88	1.50
2 x 2 x 3/4	1.60	1.60	1.97	1.67
2 x 2 x 1	1.73	1.73	2.02	1.91
2 x 2 x 1-1/4	1.90	1.90	2.10	2.05
2 x 2 x 1-1/2	2.02	2.02	2.16	2.11



SMITH - COOPER INTERNATIONAL



150# Malleable Iron Threaded Fittings

* BLACK AND HOT-DIPPED GALVANIZED
 * ISO 9001:2000 MANUFACTURER
 * SCI BRAND IS UL LISTED & FM APPROVED

*ANSI B16.3 *ANSI B16.14 *ANSI B1.20.1
 *ASTM A197 *ASTM A153 *ASME B16.39
 * NON-SCI BRAND ITEMS ARE IN BOLD

Malleable Iron Reducing Tee (con't)

Figure # 33RT / 34RT				
Size	A	B	C	Wgt
2-1/2 x 1-1/2 x 1-1/2	2.16	1.97	2.51	2.80
2-1/2 x 1-1/2 x 2	2.39	2.16	2.60	3.43
2-1/2 x 1-1/2 x 2-1/2	2.70	2.51	2.70	3.80
2-1/2 x 2 x 2	2.39	2.25	2.60	3.28
2-1/2 x 2 x 2-1/2	2.70	2.60	2.70	3.65
2-1/2 x 2-1/2 x 1/2	1.65	1.65	2.27	2.48
2-1/2 x 2-1/2 x 3/4	1.74	1.74	2.32	2.82
2-1/2 x 2-1/2 x 1	1.87	1.87	2.37	2.85
2-1/2 x 2-1/2 x 1-1/4	2.04	2.04	2.45	3.34
2-1/2 x 2-1/2 x 1-1/2	2.16	2.16	2.51	3.46
2-1/2 x 2-1/2 x 2	2.39	2.39	2.60	3.65
3 x 2 x 2	2.52	2.25	2.89	4.10
3 x 2 x 3	3.08	2.89	3.08	6.07
3 x 3 x 1/2	1.80	1.80	2.57	3.54
3 x 3 x 3/4	1.87	1.87	2.61	4.02
3 x 3 x 1	2.00	2.00	2.66	4.15
3 x 3 x 1-1/4	2.17	2.17	2.74	4.68
3 x 3 x 1-1/2	2.29	2.29	2.80	5.11
3 x 3 x 2	2.52	2.52	2.89	5.79
3 x 3 x 2-1/2	2.83	2.83	2.99	6.09
4 x 4 x 1/2	2.03	2.03	3.25	5.16
4 x 4 x 3/4	2.25	2.25	3.25	5.32
4 x 4 x 1	2.27	2.27	3.32	5.44
4 x 4 x 1-1/4	2.41	2.41	3.32	6.18
4 x 4 x 1-1/2	2.51	2.51	3.32	7.47
4 x 4 x 2	2.74	2.74	3.41	8.39
4 x 4 x 2-1/2	3.05	3.05	3.51	9.80
4 x 4 x 3	3.30	3.30	3.60	11.0
6 x 6 x 2	3.08	3.08	4.56	12.0
6 x 6 x 2-1/2	3.39	3.39	4.66	13.7
6 x 6 x 3	3.64	3.64	4.75	14.7
6 x 6 x 4	4.13	4.13	4.94	16.5
6 x 6 x 5	4.53	4.53	5.50	23.7

Malleable Iron Bull Head Reducing Tee

Figure # 33BT / 34BT				
Size	A	B	C	Wgt
1/4 x 1/4 x 3/8	0.90	0.90	0.88	0.20
3/8 x 3/8 x 1/2	1.03	1.03	1.04	0.28
1/2 x 1/2 x 3/4	1.22	1.22	1.20	0.44
1/2 x 1/2 x 1	1.36	1.36	1.26	0.55
3/4 x 1/2 x 1	1.45	1.36	1.37	0.60
3/4 x 3/4 x 1	1.45	1.45	1.37	0.62
3/4 x 3/4 x 1-1/4	1.62	1.62	1.45	0.90
1 x 1 x 1-1/4	1.67	1.67	1.58	0.95
1 x 1 x 1-1/2	1.80	1.80	1.65	1.19
1 x 1 x 2	2.02	2.02	1.73	1.63
1-1/4 x 1-1/4 x 1-1/2	1.88	1.88	1.82	1.45
1-1/4 x 1-1/4 x 2	2.10	2.10	1.90	1.70
1-1/2 x 1-1/4 x 2	2.16	2.10	2.02	1.82
1-1/2 x 1-1/2 x 2	2.16	2.16	2.02	1.86
2 x 2 x 2-1/2	2.60	2.60	2.39	3.50
2 x 2 x 3	2.88	2.88	2.55	4.40
2-1/2 x 2-1/2 x 3	3.00	3.00	2.83	5.82
3 x 3 x 4	3.60	3.60	3.30	8.62

Malleable Iron Cross

Figure 33X / 34X	Size	A	Wgt
	1/8"	0.69	0.12
	1/4"	0.81	0.19
	3/8"	0.95	0.28
	1/2"	1.12	0.44
	3/4"	1.31	0.65
	1"	1.50	0.97
	1-1/4"	1.75	1.59
	1-1/2"	1.94	1.89
	2"	2.25	2.93
	2-1/2"	2.70	5.50
	3"	3.08	8.15
	4"	3.79	14.9



SMITH - COOPER INTERNATIONAL



150# Malleable Iron Threaded Fittings

* BLACK AND HOT-DIPPED GALVANIZED
* ISO 9001:2000 MANUFACTURER
* SCI BRAND IS UL LISTED & FM APPROVED

*ANSI B16.3 *ANSI B16.14 *ANSI B1.20.1
*ASTM A197 *ASTM A153 *ASME B16.39
* NON-SCI BRAND ITEMS ARE IN BOLD

Malleable Iron Coupling

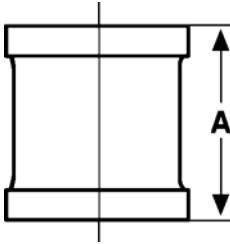
Figure 33CP / 34CP	Size	A	Wgt
	1/8"	0.96	0.06
	1/4"	1.06	0.09
	3/8"	1.16	0.13
	1/2"	1.34	0.20
	3/4"	1.52	0.29
	1"	1.67	0.48
	1-1/4"	1.93	0.74
	1-1/2"	2.15	1.00
	2"	2.53	1.45
	2-1/2"	2.88	2.40
	3"	3.18	3.30
	3-1/2"	3.50	4.80
	4"	3.69	5.65
	5"	3.75	6.90
	6"	4.75	13.3

Malleable Iron Reducing Coupling

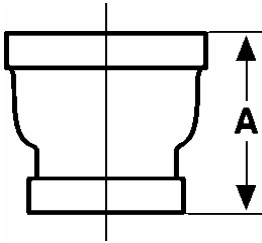
Fig. 33RC/34RC	Size	A	Wgt
	2-1/2 x 1/2	3.25	1.66
	2-1/2 x 3/4	3.25	1.64
	2-1/2 x 1	3.25	1.84
	2-1/2 x 1-1/4	3.25	2.00
	2-1/2 x 1-1/2	3.25	2.09
	2-1/2 x 2	3.25	2.50
	3 x 1/2	3.69	2.48
	3 x 3/4	3.69	2.26
	3 x 1	3.69	3.16
	3 x 1-1/4	3.69	3.22
	3 x 1-1/2	3.69	3.30
	3 x 2	3.69	3.23
	3 x 2-1/2	3.69	3.31
	4 x 1/2	4.38	3.36
	4 x 3/4	4.38	2.98
	4 x 1	4.38	3.56
	4 x 1-1/4	4.38	3.70
	4 x 1-1/2	4.38	4.20
	4 x 2	4.38	5.10
	4 x 2-1/2	4.38	5.93
	4 x 3	4.38	6.55
	5 x 2	4.56	5.60
	5 x 2-1/2	4.56	5.90
	5 x 3	4.56	5.30
	5 x 4	4.56	8.20
	6 x 2	4.25	8.08
	6 x 2-1/2	4.25	7.92
	6 x 3	4.25	7.34
	6 x 4	4.81	8.76
	6 x 5	4.25	8.50
	8 x 6	5.20	16.8

Malleable Iron Reducing Coupling

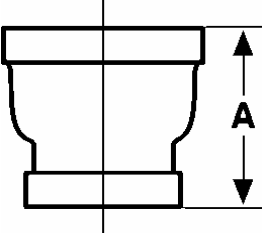
Fig. 33RC/34RC	Size	A	Wgt
	1/4 x 1/8	1.00	0.07
	3/8 x 1/8	1.13	0.11
	3/8 x 1/4	1.13	0.11
	1/2 x 1/8	1.25	0.14
	1/2 x 1/4	1.25	0.15
	1/2 x 3/8	1.25	0.16
	3/4 x 1/8	1.44	0.24
	3/4 x 1/4	1.44	0.22
	3/4 x 3/8	1.44	0.25
	3/4 x 1/2	1.44	0.26
	1 x 1/4	1.69	0.35
	1 x 3/8	1.69	0.35
	1 x 1/2	1.69	0.39
	1 x 3/4	1.69	0.42
	1-1/4 x 3/8	2.06	0.54
	1-1/4 x 1/2	2.06	0.60
	1-1/4 x 3/4	2.06	0.64
	1-1/4 x 1	2.06	0.68
	1-1/2 x 3/8	2.31	0.68
	1-1/2 x 1/2	2.31	0.77
	1-1/2 x 3/4	2.31	0.88
	1-1/2 x 1	2.31	0.90
	1-1/2 x 1-1/4	2.31	0.90
	2 x 1/2	2.81	1.15
	2 x 3/4	2.81	1.34
	2 x 1	2.81	1.40
	2 x 1-1/4	2.81	1.53
	2 x 1-1/2	2.81	1.55

Malleable Iron Locknut

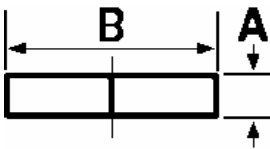
Fig. 33LN/34LN	Size	A	B	Wgt
	1/8"	0.30	0.71	0.02
	1/4"	0.34	0.90	0.04
	3/8"	0.30	1.05	0.04
	1/2"	0.38	1.27	0.08
	3/4"	0.40	1.50	0.10
	1"	0.50	1.88	0.18
	1-1/4"	0.50	2.15	0.22
	1-1/2"	0.53	2.56	0.36
	2"	0.57	3.10	0.52
	2-1/2"	0.72	4.00	1.10
	3"	0.80	4.60	1.50
	4"	0.90	5.80	2.68



SMITH - COOPER INTERNATIONAL



150# Malleable Iron Threaded Fittings

- * BLACK AND HOT-DIPPED GALVANIZED
- * ISO 9001:2000 MANUFACTURER
- * SCI BRAND IS UL LISTED & FM APPROVED

- *ANSI B16.3 *ANSI B16.14 *ANSI B1.20.1
- *ASTM A197 *ASTM A153 *ASME B16.39
- * NON-SCI BRAND ITEMS ARE IN BOLD

Malleable Iron Hex Bushing

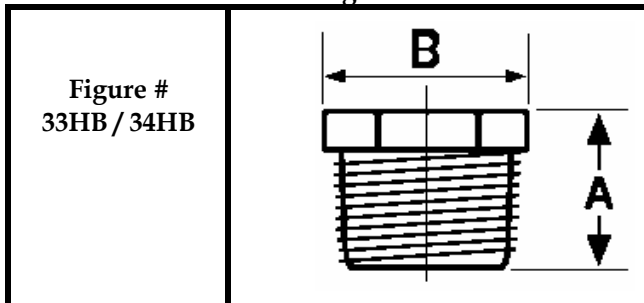

Figure # 33HB / 34HB				
Size	A	B	Wgt	Hex
1/4 x 1/8	0.61	0.66	0.03	Out
3/8 x 1/8	0.81	0.73	0.05	Out
3/8 x 1/4	0.81	0.73	0.04	Out
1/2 x 1/8	0.95	0.88	0.09	Out
1/2 x 1/4	0.95	0.88	0.08	Out
1/2 x 3/8	0.95	0.88	0.07	Out
3/4 x 1/8	0.95	1.18	0.14	Out
3/4 x 1/4	1.05	1.18	0.15	Out
3/4 x 3/8	1.05	1.18	0.14	Out
3/4 x 1/2	1.05	1.18	0.12	Out
1 x 1/8	1.12	1.15	0.19	In
1 x 1/4	1.12	1.15	0.19	In
1 x 3/8	1.16	1.15	0.23	In
1 x 1/2	1.16	1.40	0.22	Out
1 x 3/4	1.18	1.40	0.18	Out
1-1/4 x 1/8	1.16	1.15	0.32	In
1-1/4 x 1/4	1.16	1.15	0.27	In
1-1/4 x 3/8	1.20	1.15	0.25	In
1-1/4 x 1/2	1.25	1.38	0.34	In
1-1/4 x 3/4	1.25	1.80	0.38	Out
1-1/4 x 1	1.25	1.80	0.30	Out
1-1/2 x 1/8	1.30	1.18	0.45	In
1-1/2 x 1/4	1.30	1.18	0.38	In
1-1/2 x 3/8	1.30	1.18	0.39	In
1-1/2 x 1/2	1.30	1.40	0.42	In
1-1/2 x 3/4	1.30	1.66	0.45	In
1-1/2 x 1	1.30	1.95	0.47	Out
1-1/2 x 1-1/4	1.30	1.95	0.31	Out
2 x 1/4	1.40	1.18	0.64	In
2 x 3/8	1.40	1.18	0.63	In
2 x 1/2	1.50	1.37	0.55	In
2 x 3/4	1.50	1.68	0.60	In
2 x 1	1.50	1.97	0.65	In
2 x 1-1/4	1.50	2.55	0.81	Out
2 x 1-1/2	1.50	2.55	0.66	Out

Malleable Iron Hex Bushing (con't)

Size	A	B	Wgt	Hex
2-1/2 x 1/2*	1.70	3.25	1.60	Out
2-1/2 x 3/4	1.58	1.65	0.82	In
2-1/2 x 1	1.58	2.00	0.90	In
2-1/2 x 1-1/4	1.58	2.40	1.00	In
2-1/2 x 1-1/2	1.58	2.70	1.06	In
2-1/2 x 2	1.65	3.00	0.98	Out
3 x 1/2*	1.88	3.80	2.10	Out
3 x 3/4	1.75	1.70	1.48	In
3 x 1	1.70	2.00	1.44	In
3 x 1-1/4	1.70	2.40	1.40	In
3 x 1-1/2	1.70	2.70	1.44	In
3 x 2	1.80	3.70	2.20	Out
3 x 2-1/2	1.90	3.90	1.82	Out
3-1/2 x 1-1/2	1.75	2.75	2.10	In
3-1/2 x 2	1.94	1.80	2.16	In
3-1/2 x 2-1/2	1.70	4.30	2.50	Out
3-1/2 x 3	1.75	4.60	2.10	Out
4 x 1/2*	2.00	4.80	4.30	Out
4 x 3/4	2.00	2.00	2.30	In
4 x 1	1.90	2.00	2.34	In
4 x 1-1/4	1.90	2.40	2.24	In
4 x 1-1/2	1.90	2.70	2.10	In
4 x 2	1.90	3.30	2.74	In
4 x 2-1/2	2.10	4.70	3.84	In
4 x 3	2.10	4.70	3.20	Out
4 x 3-1/2	2.33	4.75	2.92	Out
5 x 2	2.05	3.30	4.26	In
5 x 2-1/2	2.10	4.00	4.55	In
5 x 3	2.10	4.70	4.95	In
5 x 4	2.10	5.80	4.36	Out
6 X 1-1/2	2.20	3.35	6.74	In
6 x 2	2.20	3.35	6.00	In
6 x 2-1/2	2.20	3.90	6.58	In
6 x 3	2.30	4.70	6.32	In
6 x 4	2.30	5.90	6.78	In
6 x 5	2.50	7.20	7.28	Out
8 x 6	2.75	9.00	16.4	Out



SMITH - COOPER INTERNATIONAL



150# Malleable Iron Threaded Fittings

* BLACK AND HOT-DIPPED GALVANIZED
* ISO 9001:2000 MANUFACTURER
* SCI BRAND IS UL LISTED & FM APPROVED

*ANSI B16.3 *ANSI B16.14 *ANSI B1.20.1
*ASTM A197 *ASTM A153 *ASME B16.39
* NON-SCI BRAND ITEMS ARE IN BOLD>

Malleable Iron Square Head Plug, Cored

Figure 33SP / 34SP	Size	A	Wgt
	1/8"	0.65	0.02
	1/4"	0.75	0.03
	3/8"	0.85	0.05
	1/2"	1.00	0.09
	3/4"	1.15	0.14
	1"	1.30	0.22
	1-1/4"	1.40	0.37
	1-1/2"	1.50	0.54
	2"	1.60	0.82
	2-1/2"	1.85	1.30
	3"	1.95	1.70
	3-1/2"	2.10	2.50
	4"	2.30	2.62
	5"	2.50	5.26
6"	2.80	6.58	

Malleable Iron Extension Piece

Fig. 33EP/34EP	Size	A	Wgt	
	3/8"	1.32	0.09	
	1/2"	1.72	0.16	
	3/4"	1.82	0.25	
	1"	2.20	0.41	
	1-1/4"	2.60	0.64	
	1-1/2"	2.65	0.82	
	2"	2.85	1.28	

Malleable Iron Floor Flange

Fig. 33FF/34FF				
Size	A	B	HOLE	Wgt
1/4"	2.83	2.00	0.31	0.28
3/8"	2.75	1.90	0.31	0.26
1/2"	3.00	2.10	0.28	0.36
3/4"	3.40	2.40	0.26	0.50
1"	3.80	2.80	0.26	0.60
1-1/4"	4.20	3.20	0.28	0.88
1-1/2"	4.60	3.45	0.30	1.08
2"	5.20	4.00	0.30	1.58
2-1/2"	6.75	5.00	0.37	2.48
3"	7.88	6.00	0.45	3.42
4"	9.50	7.00	0.45	5.70

Malleable Iron Union with Brass Seat

Fig. 33U/34U	Size	A	Wgt
	1/8"	1.32	0.16
	1/4"	1.44	0.22
	3/8"	1.61	0.32
	1/2"	1.72	0.46
	3/4"	2.02	0.58
	1"	2.19	0.90
	1-1/4"	2.26	1.20
	1-1/2"	2.47	1.64
	2"	2.75	2.40
	2-1/2"	3.25	4.16
3"	3.54	5.45	
4"	3.85	9.50	

Malleable Iron Wastnut

Fig. 33WN/34WN	Size	A	B	Wgt
	1/2"	3.15	2.00	0.32
	3/4"	3.87	2.50	0.54

Malleable Iron 45-Degree Lateral

Fig. 33LT/34LT	Size	A	B	Wgt
	3/8"	1.93	1.43	0.27
	1/2"	2.32	1.71	0.38
	3/4"	2.77	2.05	0.58
	1"	3.28	2.43	1.00
	1-1/4"	3.94	2.92	1.54
	1-1/2"	4.38	3.28	2.00
	2"	5.17	3.93	3.00
	2-1/2"	6.25	4.73	4.64
	3"	7.26	5.55	8.00
4"	8.98	6.97	14.34	

Malleable Iron Bar Plug

Fig. 33BP/34BP			
Size	A	Wgt	
4"	2.30	3.80	
5"	2.45	5.25	
6"	2.70	8.20	
8"	3.00	20.7	