



**COOPLOK™ Grooved Submittal**

**Fig. 65RC & 66RC  
Reducing Coupling**

Figure 65RC & 66RC Reducing Couplings are designed to directly connect two different sizes of pipe; no additional fittings or couplings are required.



**Material Specifications**

**Housing:**

Ductile Iron Housings conform to ASTM A-536, Grade 65-45-12

**Coating:**

- Orange Paint (rust inhibiting) - Standard Coating – Fig 65RC
- Hot Dipped Galvanized conforming to ASTM A-153 – Fig 66RC

**Coupling Gaskets:**

- Pre-lubricated Grade E-EPDM (Green Stripe)  
-30°F (-34°C) to +230°F (+110°C) Service Temperature Range  
For use with water service, diluted acids, alkali solutions, oil-free air and other chemical services. NOT FOR PETROLEUM, STEAM, or NATURAL GAS APPLICATIONS.
- Grade T-Nitrile (Orange Stripe)  
-20°F (-29°C) to +180°F (+82°C) Service Temperature Range  
For use with petroleum applications, vegetable & mineral oils, and air with oil vapors. NOT FOR USE IN HOT WATER, STEAM, or NATURAL GAS APPLICATIONS.
- Other: \_\_\_\_\_

**Nuts and Bolts:**

Zinc electroplated, heat treated, oval neck track head bolts conforming to ASTM 183 Grade 2 with a minimum tensile strength of 110,000 psi; Heavy hex nuts made of carbon steel conforming to ASTM A-563 Grade A or Grade B, or J995 Grade 2.

SCI Track Bolts are 100% Magnetic Particle Inspected  
The SCI logo appears on all COOPLOK™ track bolts.

Project Information	
Project /Job:	System:
Date:	
Engineer/Architect:	
Contractor:	
Address:	
Notes:	



# Reducing Couplings

**Fig. 65RC & 66RC**

**Reducing Coupling**

- Maximum working pressure 300 psi (20.7 bar) depending on the size and schedule of the pipe being used
- All bolts, gaskets and housings identified by SCI logo
- 100% magnetic particle inspection of each bolt. Each bolt has a minimum tensile strength of 110,000 psi
- Gaskets are pre-lubricated
- Gasket Grade E EPDM (green stripe) -30°F (-34°C) to +230°F (+110°C)
- Gasket Grade T Nitrile (orange stripe) -20°F (-29°C) to +180°F (+82°C)
- Other gasket materials available by special order
- Ductile iron housings conform to ASTM A-536
- Groove dimensions to AWWA C606
- Orange paint or hot dipped galvanized conforming to ASTM A153
- Smith-Cooper Warranty only applies to assemblies made with gaskets, housings and bolts carrying the SCI logo

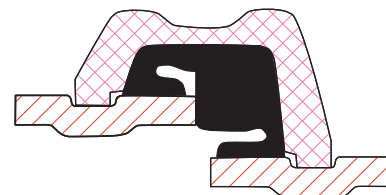
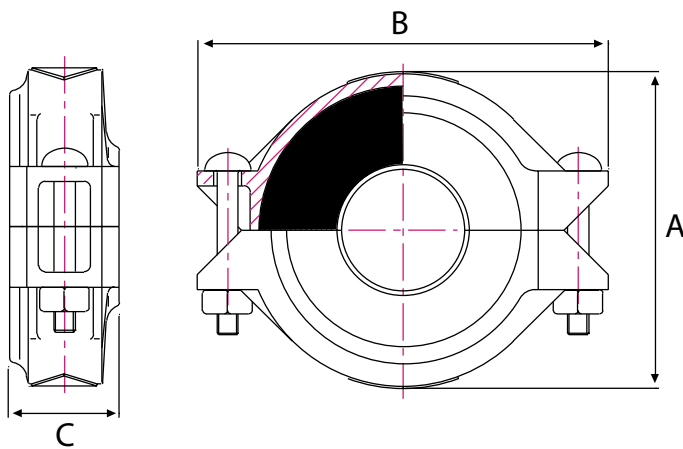

**Reducing Gasket**

Pipe Size IN / mm	Part Number		Max Pipe End Gap IN / mm	Dimensions			Deflection Degrees	Case Qty	Weight LB / kg
	Painted	Galvanized		A	B	C			
2 x 1-1/2 50 x 40	65RC3020014	66RC3020014	1/8 3.2	3.43 87.1	4.88 124.0	1.85 47.0	2.0°	26	1.9 0.9
2-1/2 x 2 65 x 50	65RC3024020	66RC3024020	1/8 3.2	3.98 101.1	5.35 135.9	1.85 47.0	1.5°	22	2.3 1.0
3 x 2 80 x 50	65RC3030020	66RC3030020	1/8 3.2	4.59 116.6	6.34 161.0	1.85 47.0	1.8°	20	3.1 1.4
3 x 2-1/2 80 x 65	65RC3030024	66RC3030024	1/8 3.2	4.51 114.6	6.34 161.0	1.85 47.0	1.8°	20	2.9 1.3
4 x 2 100 x 50	65RC3040020	66RC3040020	1/4 6.4	5.83 148.1	7.52 191.0	2.01 51.1	1.2°	10	4.8 2.2
4 x 2-1/2 100 x 65	65RC3040024	66RC3040024	1/4 6.4	5.83 148.1	7.52 191.0	2.01 51.1	1.2°	10	4.8 2.2
4 x 3 100 x 80	65RC3040030	66RC3040030	1/4 6.4	5.83 148.1	7.52 191.0	2.01 51.1	1.2°	10	4.4 2.0
6 x 4 150 x 100	65RC3060040	66RC3060040	1/4 6.4	7.99 202.9	10.35 262.9	2.01 51.1	0.9°	-	9.0 4.1
8 x 6 200 x 100	65RC3080060	66RC3080060	1/4 6.4	10.12 257.0	13.15 334.0	2.48 63.0	0.8°	-	14.6 6.6